



**GRAZER** GROUND MOWERS

**Models**

**52", 62", 72" MOWER DECKS**  
**(as used on G3100CD thru G4210CD)**  
**(liquid cooled mowers)**

**Parts List**

**TABLE OF CONTENTS**

DECALS .....	A3
GEAR BOX .....	A4
52" DECK PARTS .....	A5
52" DECK DRIVE .....	A6
62" DECK PARTS .....	A7
62" DECK DRIVE .....	A8
72" DECK PARTS .....	A9
72" DECK DRIVE .....	A10



Grazer Division, Ingersoll Equipment Company  
Winneconne, WI 54986

DECALS (Deck)

REF.	PART NO.	DESCRIPTION	REQ'D
1	C 37491	DECAL - "Whirling Blades"	1
2	C 37492	DECAL - "Caution" discharge chute	1
3	C 37493	DECAL - "Caution" grass chute	1
4	C 37494	DECAL - "Danger"	1

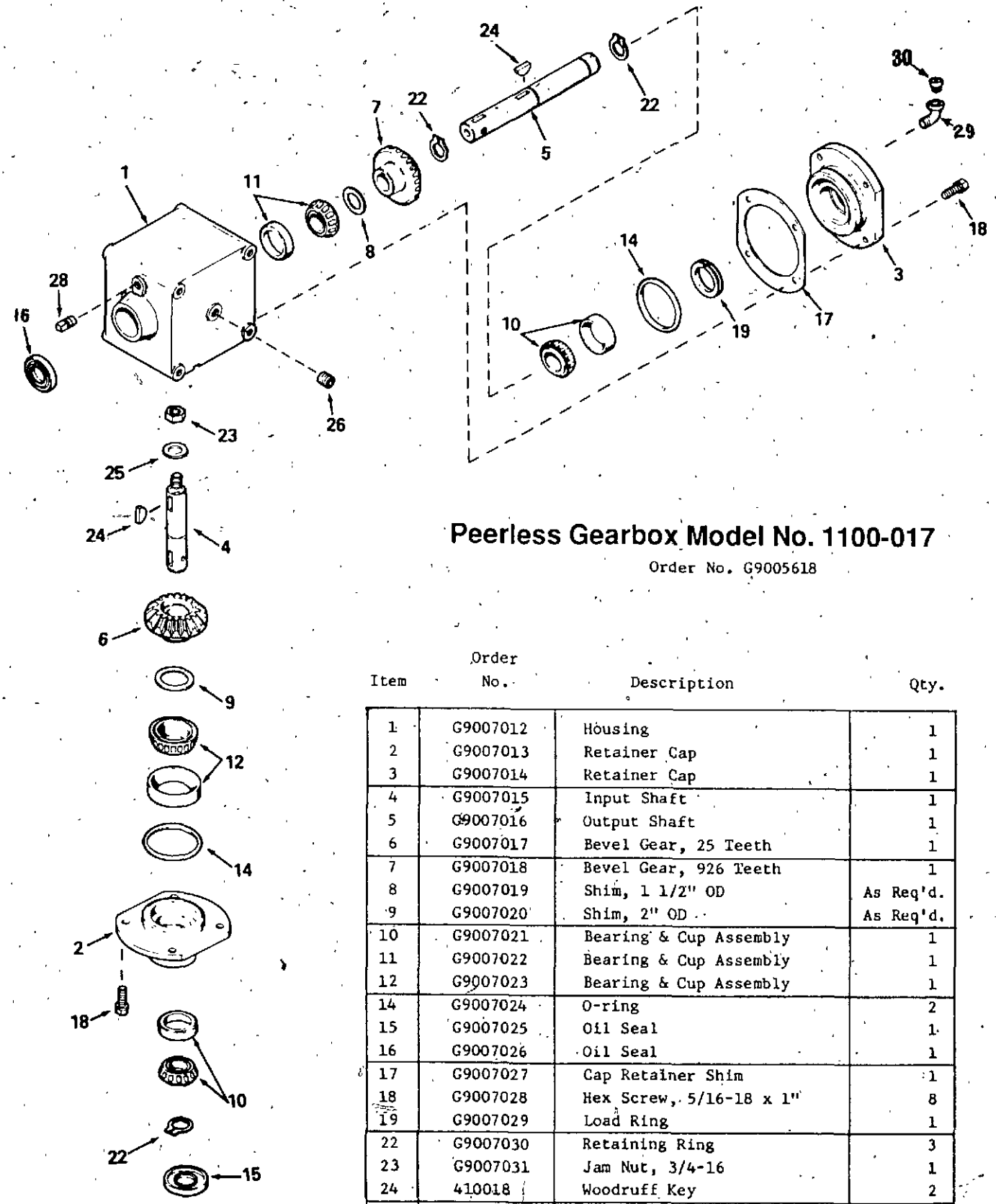
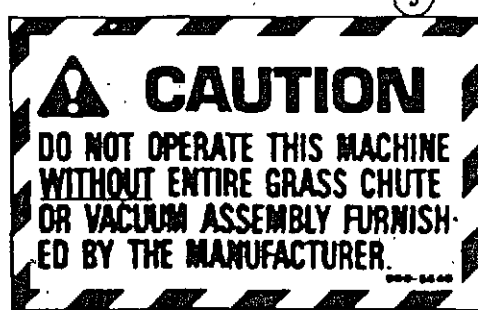
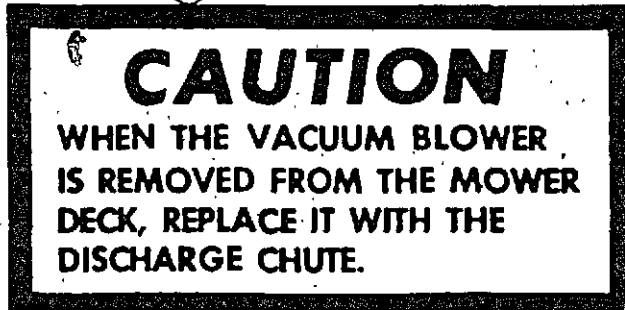

Peerless Gearbox Model No. 1100-017

Order No. G9005618

Item	Order No.	Description	Qty.
1	G9007012	Housing	1
2	G9007013	Retainer Cap	1
3	G9007014	Retainer Cap	1
4	G9007015	Input Shaft	1
5	G9007016	Output Shaft	1
6	G9007017	Bevel Gear, 25 Teeth	1
7	G9007018	Bevel Gear, 926 Teeth	1
8	G9007019	Shim, 1 1/2" OD	As Req'd.
9	G9007020	Shim, 2" OD	As Req'd.
10	G9007021	Bearing & Cup Assembly	1
11	G9007022	Bearing & Cup Assembly	1
12	G9007023	Bearing & Cup Assembly	1
14	G9007024	O-ring	2
15	G9007025	Oil Seal	1
16	G9007026	Oil Seal	1
17	G9007027	Cap Retainer Shim	1
18	G9007028	Hex Screw, 5/16-18 x 1"	8
19	G9007029	Load Ring	1
22	G9007030	Retaining Ring	3
23	G9007031	Jam Nut, 3/4-16	1
24	410018	Woodruff Key	2
25	G9007033	Flatwasher	1
26	G9007034	Pipe Plug, 1/4-18	2
28	G9007035	Pipe Plug, 1/8-27	2
29	11108	Street Elbow, 1/8" x 90°	1
30	G9007004	Relief Valve	1

52" Deck Parts

Item	Order No.	Description	Qty.	Item	Order No.	Description	Qty.
1	G3250000G	Deck, 52"	1	14	G9004004	Wheel Assembly.	2
2	G3250002G	Outside Cover, LH	1		G9004006	Tire, 11 x 4.00-5	2
3	G3250003G	Outside Cover, RH	1		G9003505	Wheel Assembly Bearing	4
4	G3250004G	Center Cover, LH	1	15	314022C	Hex Bolt, 1/2-13 x 6 1/2"	2
5	G3250005G	Center Cover, RH	1	16	G9006096	Wing Bolt	4
6	G3450008	Drive Shaft Cover	1	17	G9006092	Handle Nut	4
7	G3200015G	Fas-tatch Foot Guard	1	18	G9002044	10 Amp Circuit Breaker	1
8	G3200016G	Fas-tatch Foot Guard Mount	1	19	G9005510	Set Collar	2
9	G3200014	Shoe, LH Side	1	20	G9003501	Bearing	4
10	G3000044	Gauge Wheel Mount Bracket	2	21	G9005559	Anti-scalp Roller	1
11	G3000043	Gauge Wheel Mount	2	22	G3000038	Shaft & Bracket	1
12	G3300007	Gauge Wheel Fork	2	23	G9005615	Fas-tatch Pin	1
13	G2000017	Axle	2	24	41956	Clevis Pin, 1/2" x 2"	2
				25	49207	Hair Pin Cotter, .120" x 2 1/2"	2

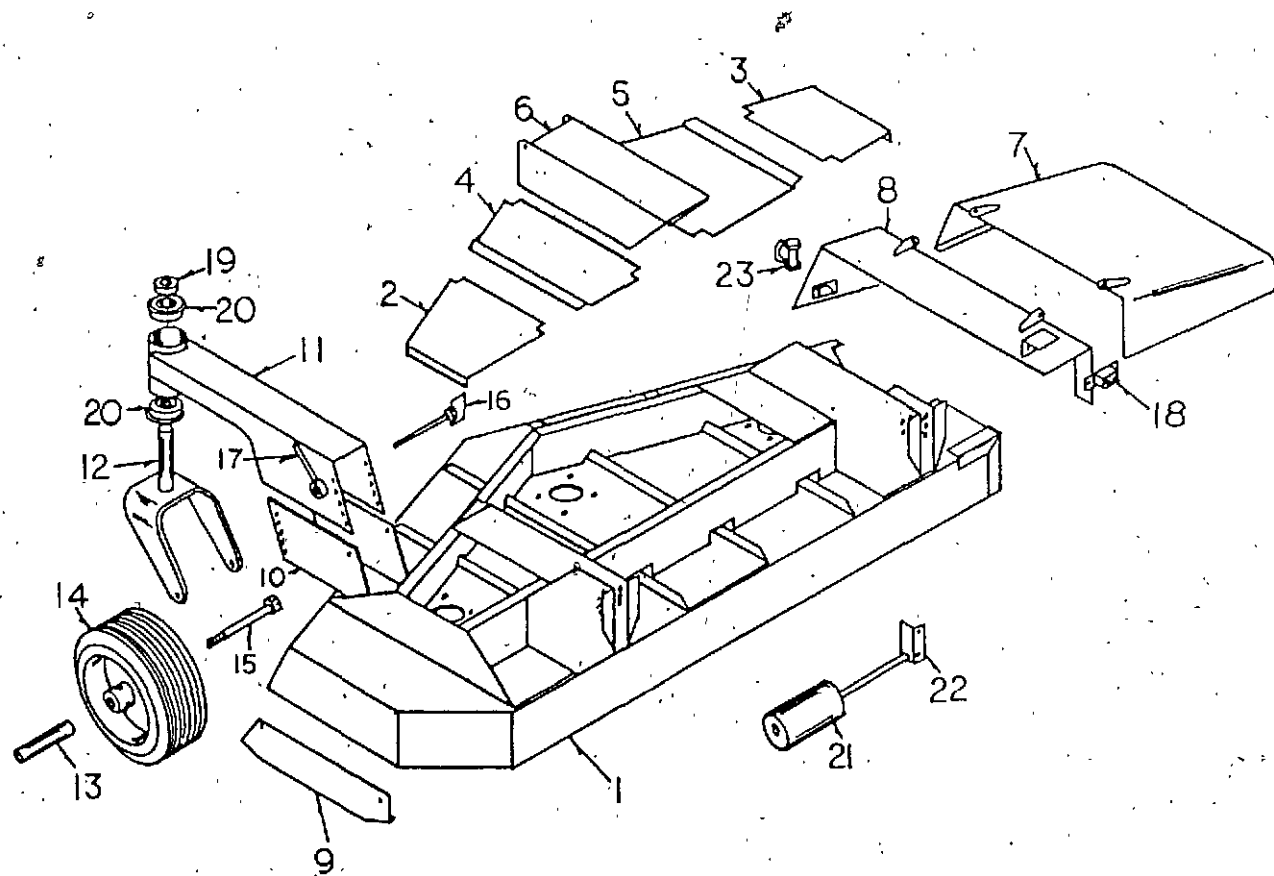

52" Deck Drive

Item	Order No.	Description	Qty.	Item	Order No.	Description	Qty.
1	G3000015	Belt Tightener	2	15	G9003506	Spindle Bearing, 7/8"	6
2	G3000025	Housing Spindle	3	16	G9005534	Spring Washer	3
3	G3000016	Spacer	1	17	G9005814	Blade	3
4	G3250001G	Gearbox Mount	1	18	G9006002	Mech. Washer, 14 GA	-
5	G3000026	Short Spindle Shaft	2	19	G9002537	Taper Hub, 7/8"	1
6	G3000033	Long Spindle Shaft	1	20	G9005618	Gearbox	1
7	G3000027	Spindle Shaft Spacer	3	21	30206H5C	Bolt, 3/8-24 x 1 1/4", GR5	3
8	G9002518	Idler Pulley	2	22	45053	Grease Zerk	3
9	G9002531	Double Pulley, 4.6"	1	23	40611	Key Stock, 3/16" x 3/16" x 1"	3
10	G9002511	Single Pulley, 5"	3	24	G3000017	Spindle Washer, 5/16", 10 GA	3
11	G9002539	Double Pulley, 4.2"	1	25	300115C	Hex Tap Bolt, 1/4-20 x 4"	1
12	G9002546	Taper Hub	1	26	30103H5C	Hex Capscrew, 5/16-24 x 3/4", GR5	3
13	G9003012	Belt, B x 55	1	27	410018	Woodruff Key, 1/4" x 7/8"	2
14	G9003017	Belt, B x 58	1	28	G6000000	Spindle Housing Assembly	-

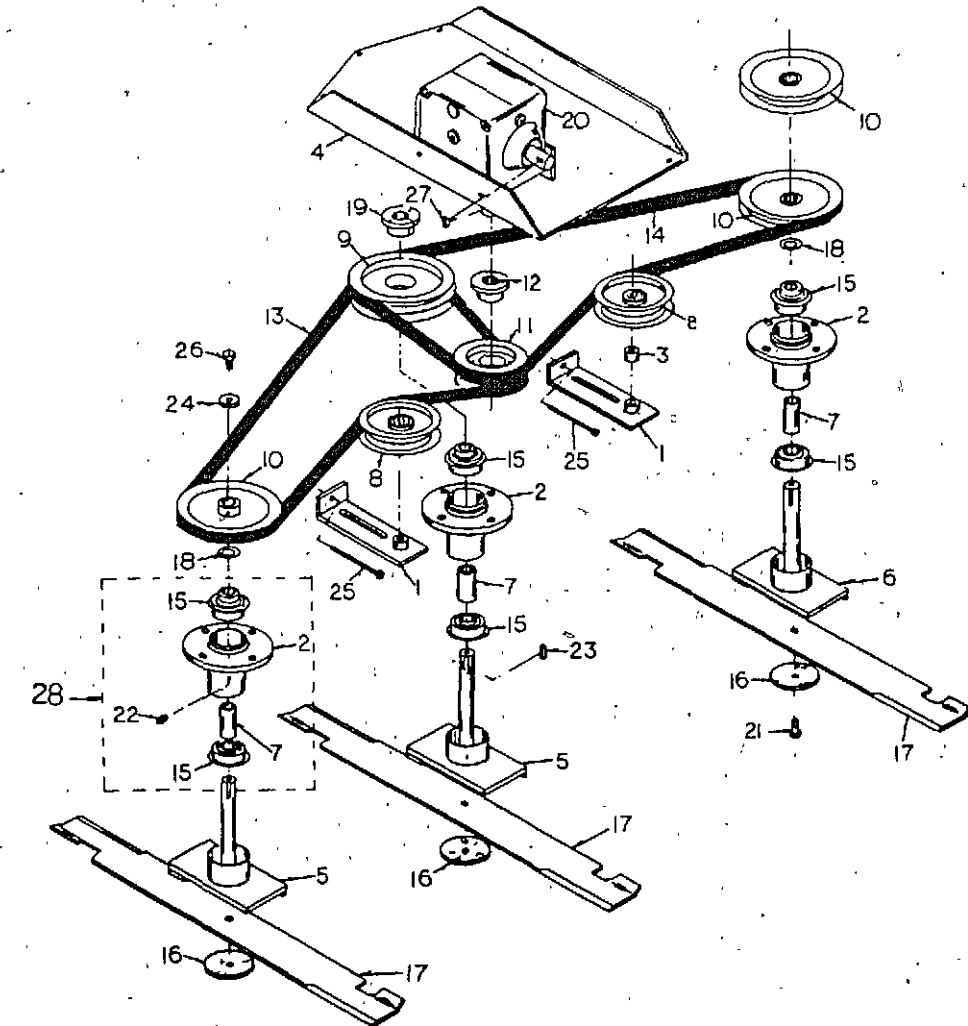

# 62" Deck Parts

Item No.	Description	Qty.	Order No.	Description	Qty.
1	G335000G Deck, 62"	1	15	G9004004 Wheel Assembly	2
2	G3350002G Outside Cover, LH	1		G9004006 Tire, 11 x 4.00-5	2
3	G3350003G Outside Cover, RH	1		G9004005 Rim, 5"	-
4	G3350004G Center Cover, LH	1		G9003505 Wheel Assembly Bearing	4
5	G3350005G Center Cover, RH	1	16	314022C Hex Bolt, 1/2-13 x 6 1/2"	2
6	G3450008 Drive Shaft Cover	1	17	G9006096 Wing Bolt	4
7	G3300027G Fas-tatch Foot Guard	1	18	G9006092 Handle Nut	4
8	G3300028G Fas-tatch Foot Guard Mount	1	19	G9005510 Set Collar	2
9	G3300011 Shoe, RH Side	1	20	G9003501 Bearing	4
10	G3300008 Shoe, LH Side	1	21	G9005612 Short Anti-scalp Roller (Front)	1
11	G3000044 Gauge Wheel Mount Bracket	2	22	G9005559 Long Anti-scalp Roller	1
12	G3000043 Gauge Wheel Mount	2	23	G3000038 Shaft & Bracket	1
13	G3300007 Gauge Wheel Fork	2	24	G9002044 10 Amp Circuit Breaker	1
14	G2000017 Axle	2	25	G9005615 Fas-tatch Pin	1
			26	41956 Clevis Pin, 1/2" x 2"	2
			27	49207 Hair Pin Cotter, .120 x 2 1/2"	2

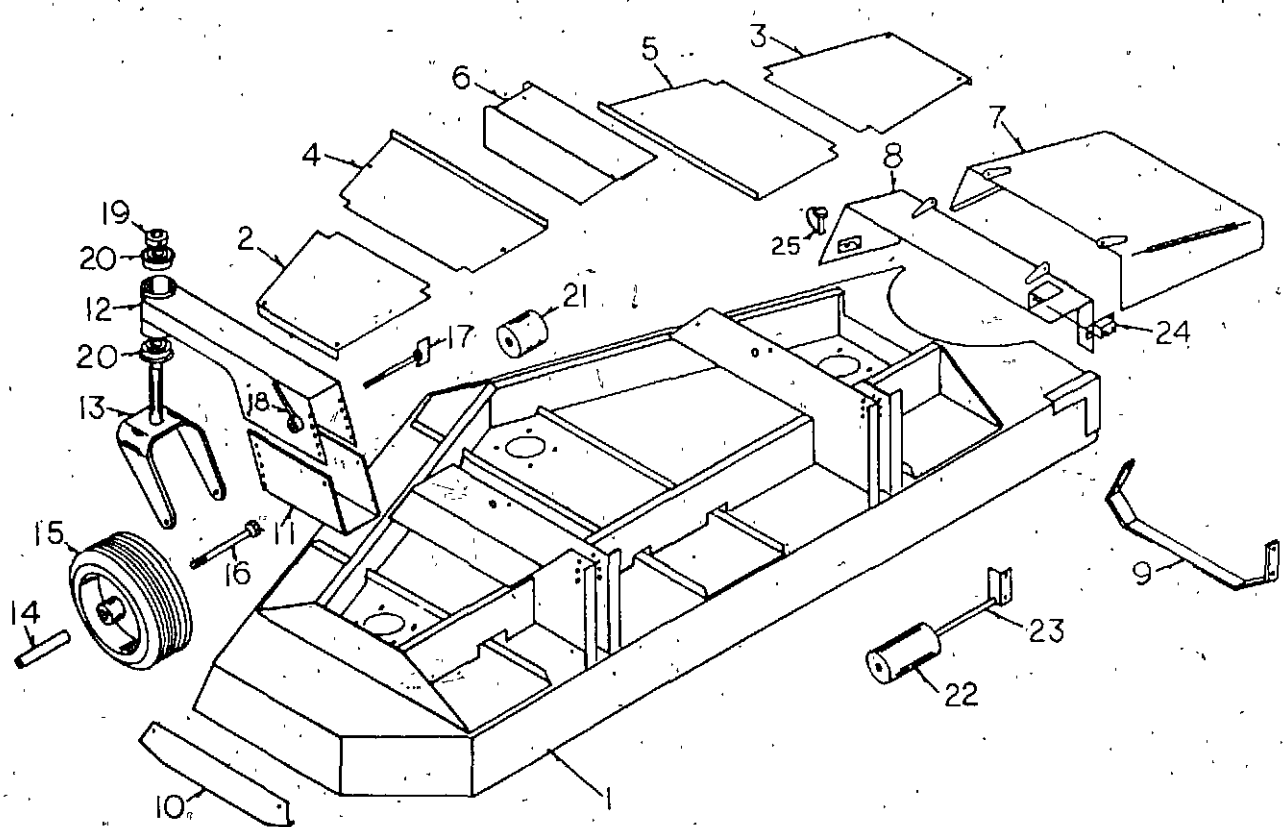

# 62" DECK DRIVE

REF. NO.	PART NO.	AMT.	REQ'D DESCRIPTION	REF. NO.	PART NO.	AMT.	REQ'D DESCRIPTION
1.	300-0015	2	BELT TIGHTENER	14.	900-3020	1	BELT 68
2.	300-0031	3	HOUSING SPINDLE	15.	900-3506	6	BEARING, 7/8" SPINDLE
3.	300-0016	1	SPACER	16.	900-5534	3	SPRING WASHER
4.	335-0001	1	GEAR BOX MOUNT	17.	900-5529	3	BLADES
5.	300-0032	2	SPINDLE SHAFT (SHORT)	18.	900-6002	-	MECH. WASHER 14GA
6.	300-0040	1	SPINDLE SHAFT (LONG)	19.	900-2548	1	7/8 TAPER HUB
7.	300-0034	3	SPINDLE SPACER	20.	900-5618	1	GEAR BOX
8.	900-2518	2	IDLER PULLEY	21.	900-6080	3	3/8-24 x 1 1/4 BOLT
9.	900-2540	1	6.2 DOUBLE PULLEY	22.	900-5620	3	GREASE ZERK
10.	900-2512	3	6 SINGLE PULLEY	23.	300-0021	4	3/16 KEY STOCK
11.	900-2539	1	4.2 DOUBLE PULLEY (4 CYL)	24.	300-0017	3	SPINDLE WASHER 5/16 10 GA
11.	900-2538	1	4.0 DOUBLE PULLEY (3 CYL)	25.	900-6034	2	1/4-20 x 4 ALTHREAD
12.	900-2546	1	TAPER HUB	26.	900-6053	3	5/16-24 x 3/4 HEX
12.	900-2547	1	H TAPER HUB (3 CYL)	27.	900-5661	2	1/4 x 3/4 HALF MOON KEY
13.	900-3021	1	BELT 63	28.	600-0001	3	HOUSING ASSEMBLY

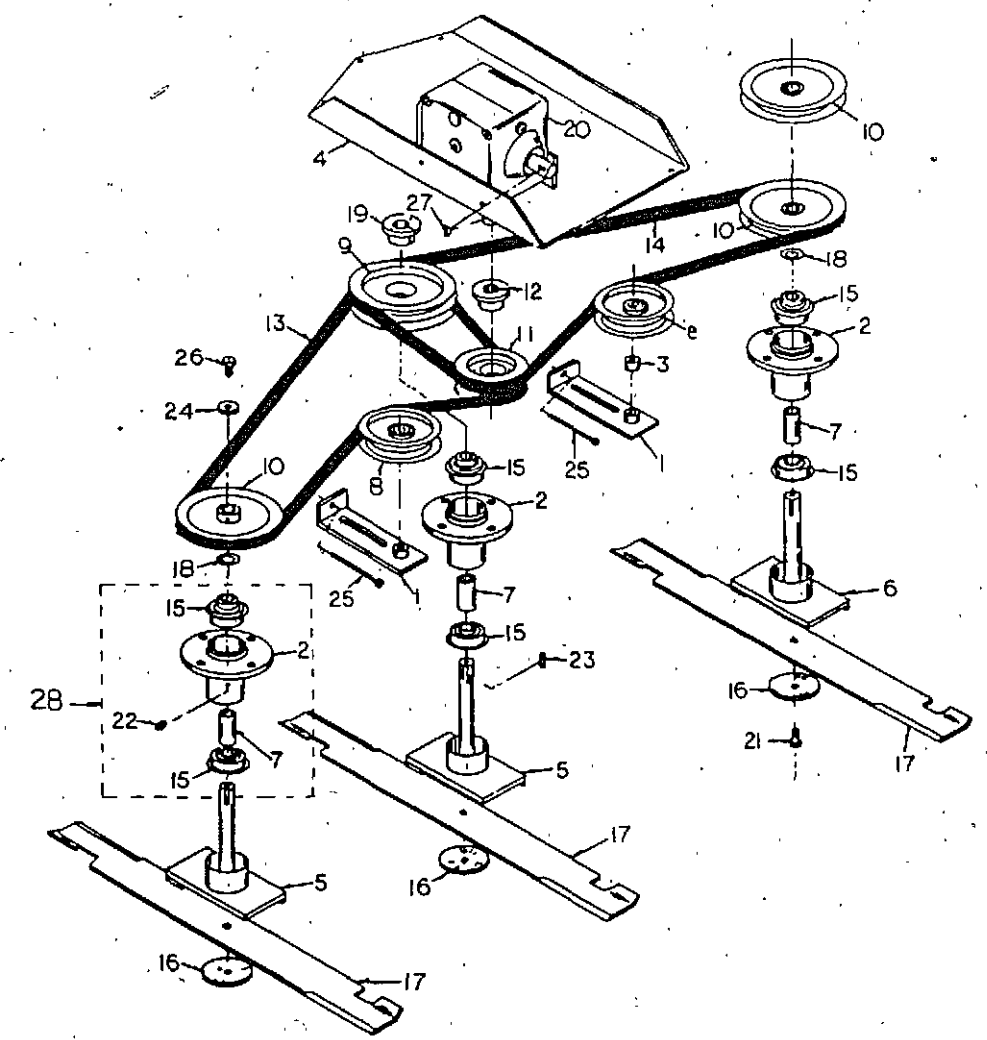

### 72" Deck Parts

Item	Order No.	Description	Qty.	Item	Order No.	Description	Qty.
1	G3450000G	Deck, 72"	1	15	G3300007	Gauge Wheel Fork	2
2	G3450001	Side Roller-Shaft, RH	1	16	G2000017	Axle	2
3	G3450002	Side Roller Shaft, LH	1	17	G9003501	Bearing	4
4	G3450003	Shoe, LH Side	1	18	G9005510	Set Collar, 1"	2
5	G3450005	Gauge Wheel Mount	2	19	314022C	Hex Bolt, 1/2-13 x 6 1/2"	2
6	G3450006	Gauge Wheel Mount Nut	2	20	G9004004	Wheel Assembly	2
7	G3450007	Gauge Wheel Mount Bolt	2		G9004006	Tire, 11 x 4.00-5	2
8	G3450008G	Drive Shaft Cover	1		G9004005	Rim, 5"	-
9	G3450009G	Center Cover, RH	1		G9003505	Wheel Assembly Bearing	4
10	G3450010G	Center Cover, LH	1	21	G9005612	Anti-scalp Roller	3
11	G3450011G	Outside Cover, RH	1	22	G9002044	10 Amp Circuit Breaker	1
12	G3450012G	Outside Cover, LH	1	23	G9006043	Wing Bolt, 1/4-20 x 1/2"	6
13	G3300003G	Foot Guard	1	24	41956	Clevis Pin, 1/2" x 2"	2
14	G3300011	Shoe, RH Side	1	25	49207	Hair Pin Cotter, .120 x 2 1/2"	2

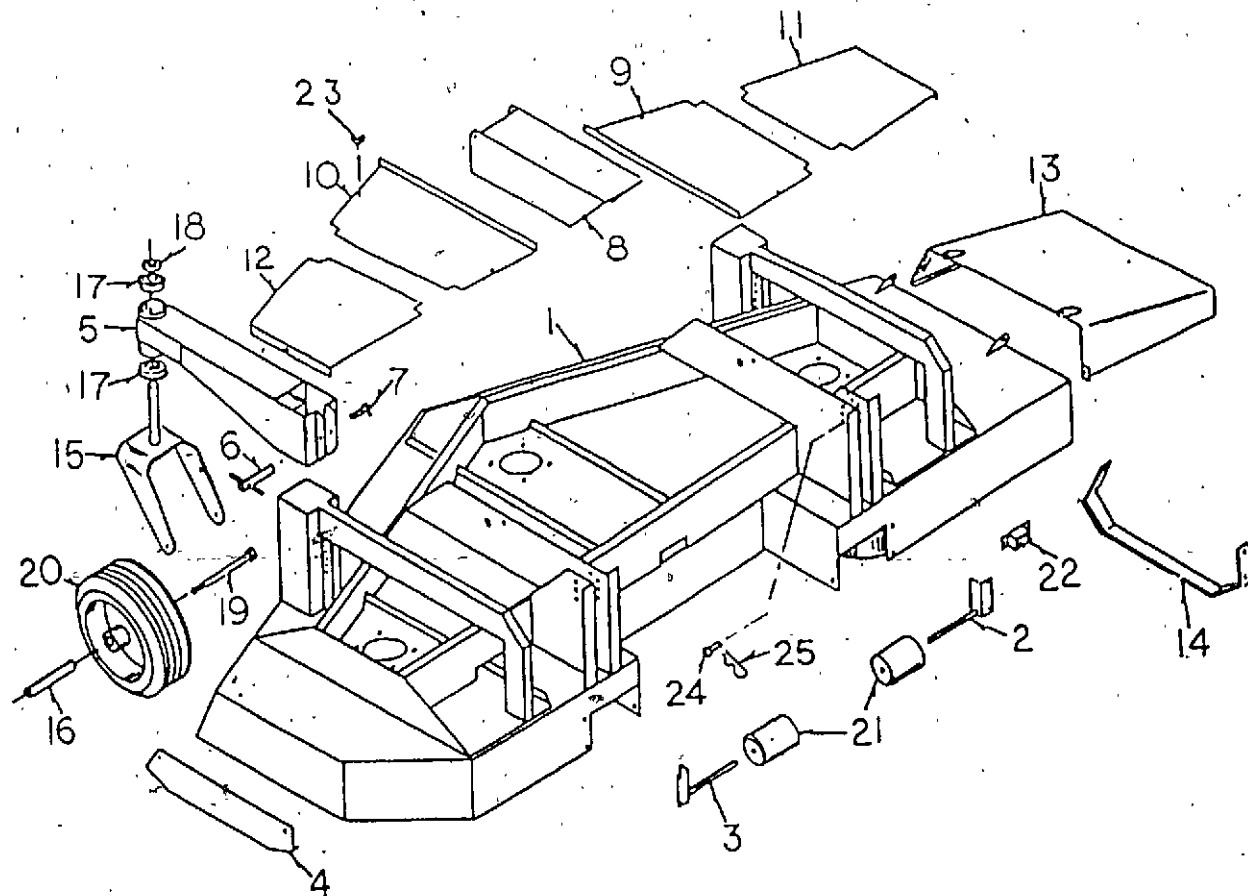

### 72" Deck Drive

Item	Order No.	Description	Qty.	Item	Order No.	Description	Qty.
1	G3300012	Belt Tightener	2	15	G9003513	Spindle Bearing, 1"	6
2	G3000025	Housing Spindle	3	16	G9005534	Spring Washer	3
3	G3000016	Spacer	1	17	G9005608	Blade	3
4	G3450004G	Gearbox Mount	1	18	G9006000	Machine Washer, 14 GA	17
5	G3450013	Short Spindle Shaft	2	19	G9006001	Machine Washer, 10 GA	3
6	G3450014	Long Spindle Shaft	1	20	G9005618	Gearbox	1
7	G3450015	Spindle Shaft Spacer	3	21	30206H5C	Bolt, 3/8-24 x 1 1/4", GR5	6
8	G9002521	Idler Pulley	2	22	45053	Grease Zerk	3
9	G9002529	Double Pulley, 8"	1	23	40621	Key Stock, 1/4" x 1/4" x 1"	4
10	G9002530	Single Pulley, 8"	2	24	G9006093	Spindle Washer, 3/8", 10 GA	3
11	G9002531	Double Pulley, 4.6"	1	25	300115C	Hex Tap Bolt, 1/4-20 x 4"	1
12	G9002532	Taper Hub	1	26	300118C	Hex Tap Bolt, 1/4-20 x 5 1/2"	1
13	G9003015	Belt, B x 78	1	27	410018	Woodruff Key, 1/4 x 7/8"	2
14	G9003016	Belt, B x 81	1	28	G6000002	Spindle Housing Assembly	-

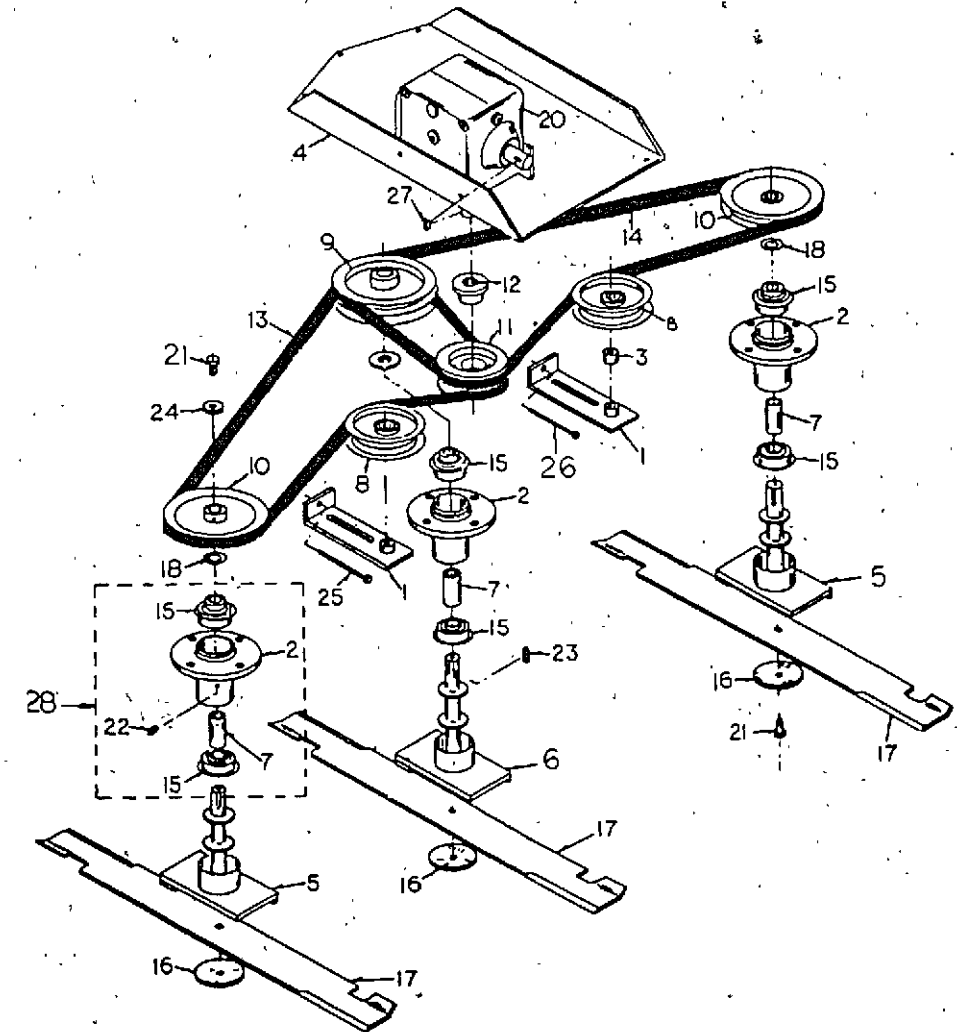



**GRAZER** GROUND MOWERS

**Models**

**EM52, EM62, EM72  
ESTATE MOWERS**

**Parts List**

**TABLE OF CONTENTS**

EM52 DECK .....	B4
EM52 CARRIAGE .....	B6
EM62 DECK .....	B8
EM62 CARRIAGE .....	B10
EM72 DECK .....	B12
EM72 CARRIAGE .....	B14
IID DRIVE SHAFT .....	C1
GEAR BOX .....	C2



Grazer Division, Ingersoll Equipment Company  
Winneconne, WI 54986

## EM52 DECK

Item	Part No.	Description	Qty.
1	30206H5C	Hex Capscrew, 3/8-24 x 1 1/4", GR5	3
2	G9005534	Spring Washer	3
3	G9005710	Blade, 52"	3
4	G3000026	Spindle Shaft, 7/8"	3
5	G9003506	Spindle Bearing, 7/8"	6
6	33002C	Hex Nut, 5/16-18	22
7	35002C	Lockwasher, 5/16"	25
8	37021C	Carriage Bolt, 5/16-18 x 3/4"	22
9	G3200014	Shoe, LH	1
10	G3260000G	Deck, 52"	1
11	G3000025	Spindle Housing, 52"	3
12	G9006002	Machine Washer, 14 Ga. x 7/8"	10
13	G9003024	Blade Drive Belt	2
14	G9002507	Spindle Pulley	2
15	G3000017	Spindle Washer	3
16	30103H5C	Hex Capscrew, 5/16-24 x 3/4", GR5	3
17	G3260009G	Pulley Box Cover, LH	1
18	G9006043	Thumb Screw, 1/4-20 x 1/2"	2
19	40611	Key, 3/16" x 3/16" x 1"	3
20	300311H5C	Hex Tap Bolt, 3/8-16 x 3", GR5	1
21	G3000027	Spindle Spacer	3
22	G3260002	Gearbox Adjustment Plate	1
23	G3260001	Gearbox Mount	1
24	2736461	Gearbox, 1 to 2.5 Ratio, 540 RPM	1
25	31407H5C	Hex Capscrew, 1/2-13 x 1 1/2", GR5	4

26	G3260008G	Pulley Box Cover, RH	1
27	2736462	Quick Disconnect IID Shaft	1
28	G9005549	Decal, Danger	1
29	G3200003G	Foot Guard	1
30	31306H5C	Hex Capscrew, 7/16-14 x 1 1/4", GR5	12
31	35004C	Lockwasher, 7/16"	12
32	33004C	Hex Nut, 7/16-14	12
34	G9002516	Spindle Pulley, 52"	1
35	35005C	Lockwasher, 1/2"	4
36	33005C	Hex Nut, 1/2-13	4
37	35003C	Lockwasher, 3/8"	8
38	33003C	Hex Nut, 3/8-16	8
39	38003C	Flatwasher, 3/8"	4
40	31205H5C	Hex Capscrew, 3/8-16 x 1", GR5	4
41	K9002530	Hex Capscrew, M8 x 12	1
42	38001C	Flatwasher, 1/4"	1
43	2738608	ID Tag/No Oil in Gearbox	1
44	G9002545	Double Belt Drive Pulley, 10" OD	1
45	G9002537	Taper Bushing, SDS x 7/8"	1
46	G9005542	Decal, Caution - Whirling Blade	1
47	G9005540	Decal, Caution - Grass Chute	1
48	40621	Key, 1/4" x 1/4" x 1"	1
49	45051	Self-tapping Grease Zerk, 1/4-28	3

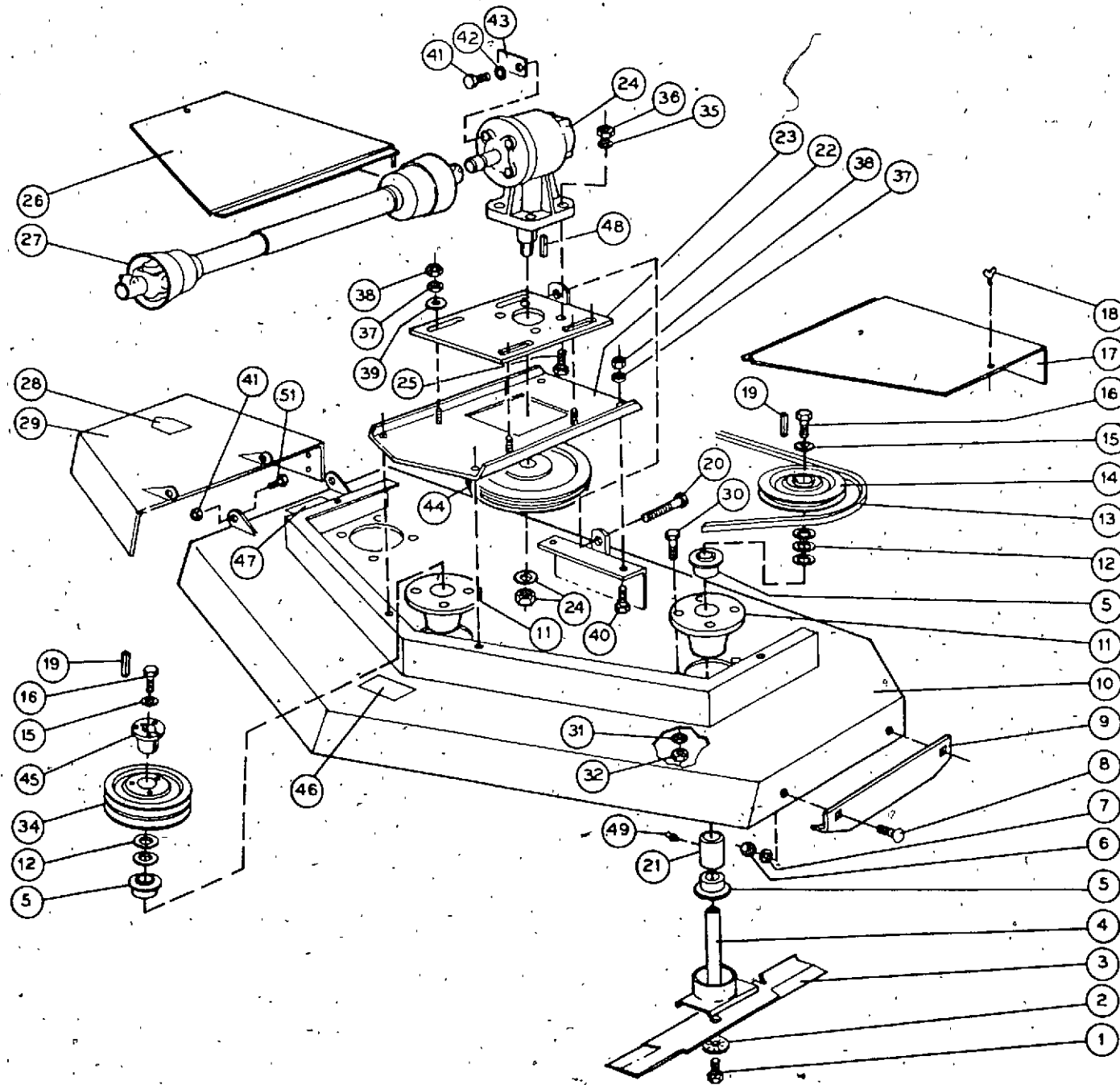

## EM52 CARRIAGE

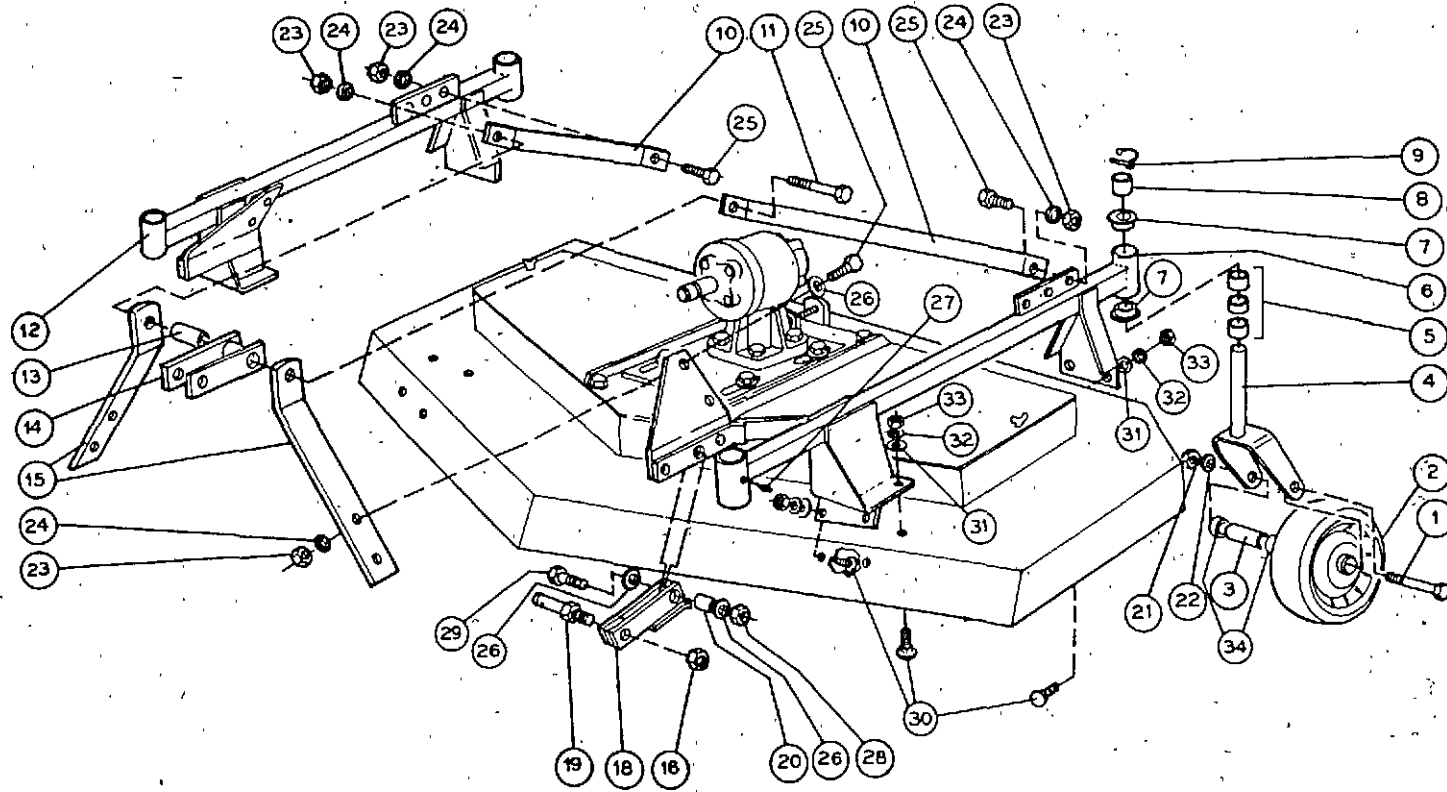

Item	Part No.	Description	Qty.
1	312018H5C	Hex Capscrew, 3/8-16 x 4 1/2", GR5	4
2	G9004007	Gauge Wheel	4
3	G3260016	Gauge Wheel Axle, 3/8" ID	4
4	G3260010	Gauge Wheel Fork	4
5	G3260012	Long Spacer	12
6	G3260007	Gauge Wheel Mount, LH	1
7	G9003501	Drive Wheel Bearing	8
8	G3260011	Short Spacer	4
9	F102	Klick Pin, 1/4"	4
10	G3360006	Upright Support	2
11	314020H5C	Hex Capscrew, 1/2-13 x 5 1/2", GR5	1
12	G3260006	Gauge Wheel Mount, RH	1
13	G3260013	Flexible Link Bushing	1
14	G3260003	Flexible Link	1
15	G3260004	Upright Brace	2
16	G9006300	Locknut, 7/8-14	2
18	G3360005	Knee	2
19	2738609	Category I Lift Pin, 7/8-14	2
20	G3360007	Knee Bushing	2
21	33003C	Hex Nut, 3/8-16	4
22	350035	Lockwasher, 3/8"	4
23	33005C	Hex Nut, 1/2-13	7
24	35005C	Lockwasher, 1/2"	7
25	31407H5C	Hex Capscrew, 1/2-13 x 1 1/2", GR5	6
26	38005C	Flatwasher, 1/2"	8
27	45051	Self-tapping Grease Zerk, 1/4-28	4
28	32945C	Elastic Stop Nut, 1/2-13	2
29	314011H5C	Hex Capscrew, 1/2-13 x 2 1/2", GR5	2
30	37021C	Carriage Bolt, 5/16-18 x 3/4"	12
31	38002C	Flatwasher, 5/16"	12
32	35002C	Lockwasher, 5/16"	12
33	33002C	Hex Nut, 5/16-18	12
34	G3000042	Gauge Wheel Spacer	8



## EM62 DECK

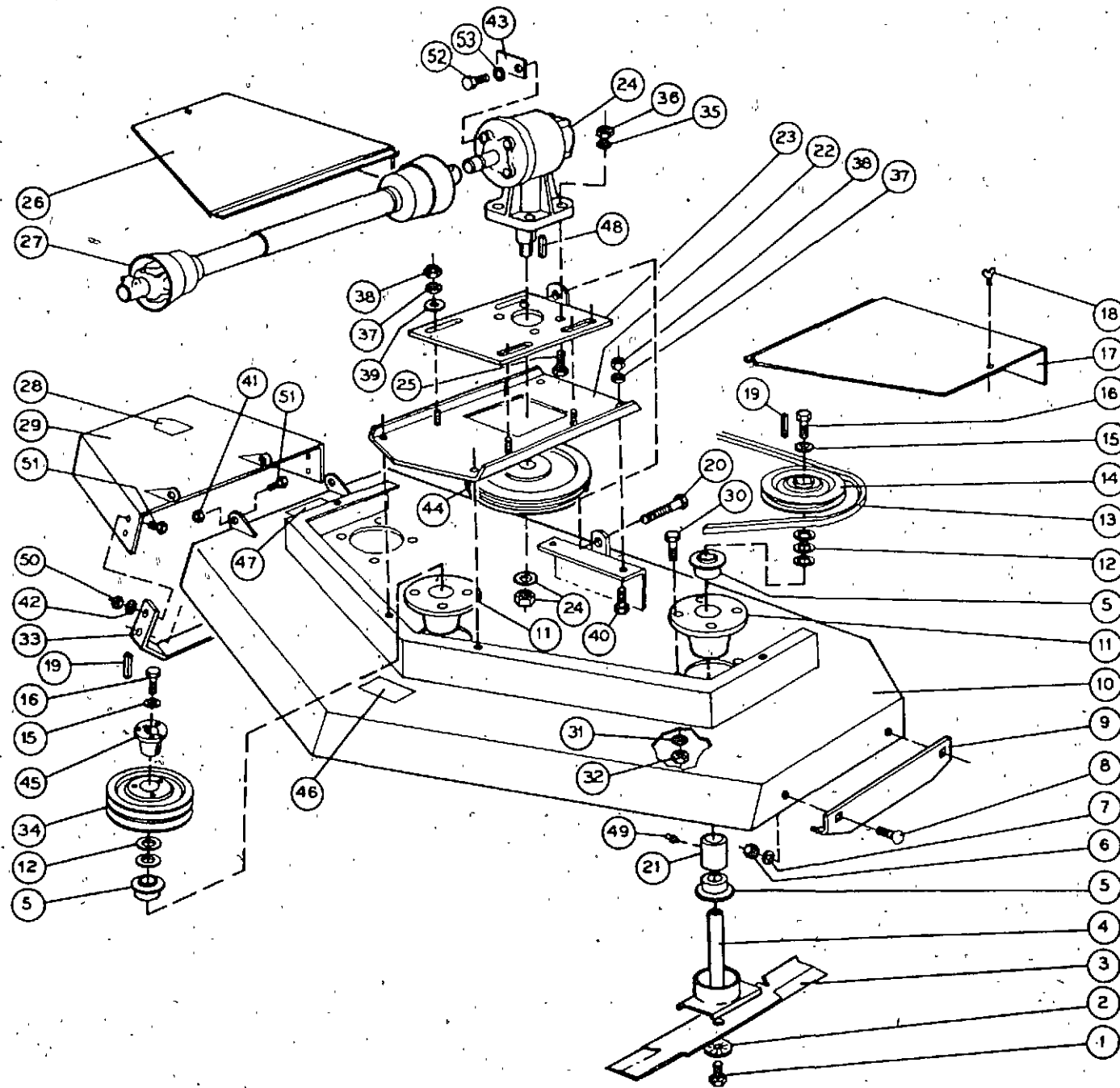

Item	Part No.	Description	Qty.
1	30206H5C	Hex Capscrew, 3/8-24 x 1 1/4", GR5	3
2	G9005534	Spring Washer	3
3	G9005730	Blade, 62"	3
4	G3000032	Spindle Shaft	3
5	G9003506	Spindle Bearing, 7/8"	6
6	33002C	Hex Nut, 5/16-18	22
7	35002C	Lockwasher, 5/16"	25
8	37021C	Carriage Bolt, 5/16-18 x 3/4"	22
9	G3300008	Shoe, LH	1
10	G3360000G	Deck, 62"	1
11	G3000031	Spindle Housing, 62"	3
12	G9006002	Machine Washer, 14-Ga. x 7/8"	8
13	G9003020	Deck Belt, 62"	2
14	G9002511	Spindle Pulley	2
15	G3000017	Spindle Washer	3
16	30103H5C	Hex Capscrew, 5/16-24 x 3/4", GR5	3
17	G3360002G	Pulley Box Cover, LH	1
18	G9006043	Thumb Screw, 1/4-20 x 1/2"	2
19	40611	Key, 3/16" x 3/16" x 1"	3
20	300311H5C	Hex Tap Bolt, 3/8-16 x 3", GR5	1
21	G3000034	Spindle Spacer	3
22	G3260002	Gearbox Adjustment Plate	1
23	G3260001	Gearbox Mount	1
24	2736461	Gearbox, 1 to 2.5 Ratio, 540 RPM	1
25	31407H5C	Hex Capscrew, 1/2-13 x 1 1/2", GR5	4
26	G3360001G	Pulley Box Cover, RH	1
27	2736462	Quick Disconnect IID Shaft	1
28	G9005549	Decal, Danger	1
29	G3300003G	Foot Guard	1
30	31306H5C	Hex Capscrew, 7/16-14 x 1 1/4", GR5	12
31	35004C	Lockwasher, 7/16"	12
32	33004C	Hex Nut, 7/16-14	12
33	G3300011	Shoe, RH	1
34	G9002531	Spindle Pulley	1
35	35005C	Lockwasher, 1/2"	4
36	33005C	Hex Nut, 1/2-13	4
37	35003C	Lockwasher, 3/8"	8
38	33003C	Hex Nut, 3/8-16	8
39	38003C	Flatwasher, 3/8"	4
40	31205H5C	Hex Capscrew, 3/8-16 x 1", GR5	4
41	32941C	Elastic Stop Nut, 1/4-20	2
42	35001C	Lockwasher, 1/4"	6
43	2738608	ID Tag/No Oil in Gearbox	1
44	G9002545	Double Belt Drive Pulley, 10" OD	1
45	G9002537	Taper Bushing, SDS x 7/8"	1
46	G9005542	Decal, Caution - Whirling Blade	1
47	G9005540	Decal, Caution - Grass Chute	1
48	40621	Key, 1/4" x 1/4" x 1"	1
49	45051	Self-tapping Grease Zerk, 1/4-28	3
50	33001C	Hex Nut	6
51	31003H5C	Hex Capscrew, 1/4-20 x 3/4", GR5	8
52	K9002530	Hex Capscrew, M8 x 12	1
53	38001C	Flatwasher, 1/4"	1

## EM62 CARRIAGE

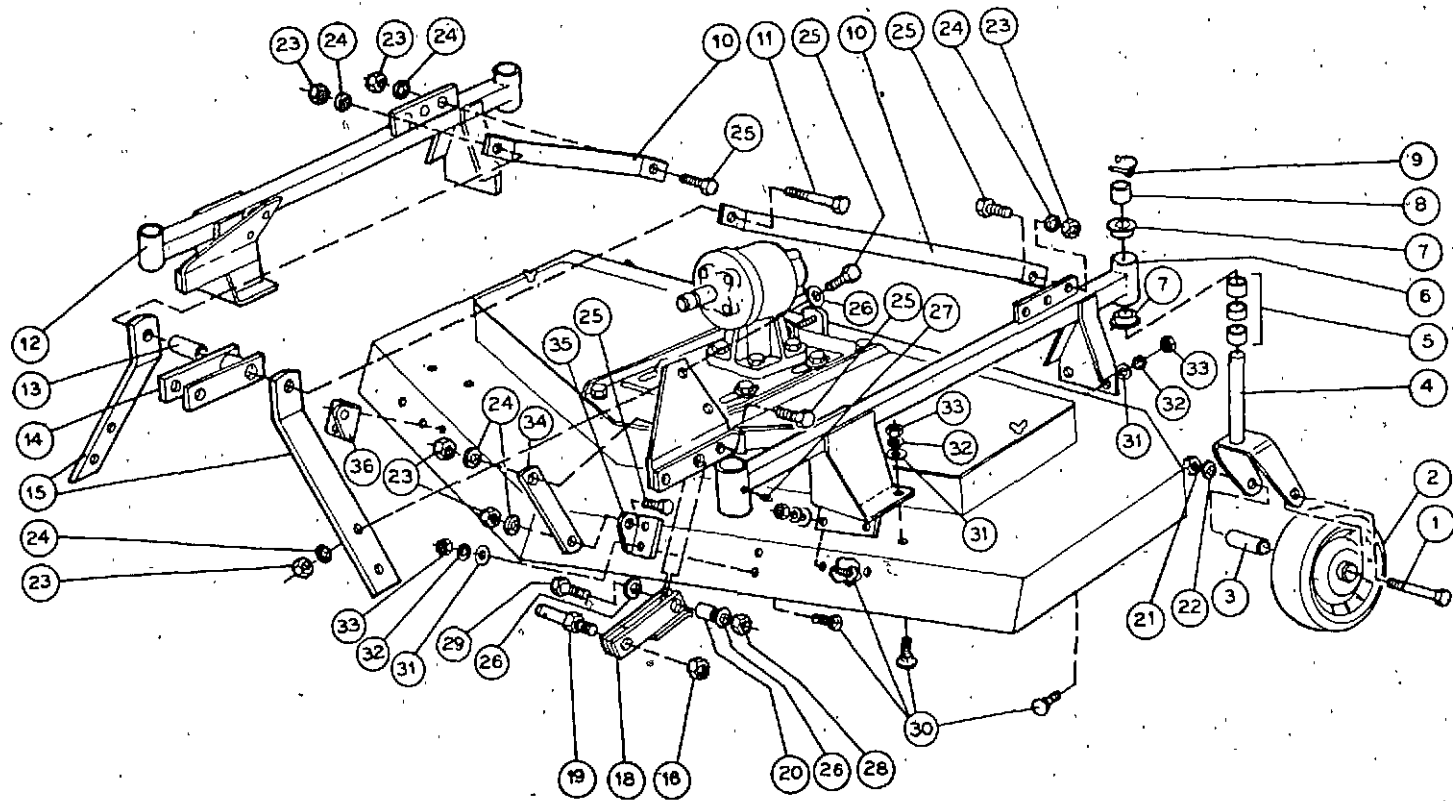

Item	Part No.	Description	Qty.
1	312018H5C	Hex Capscrew, 3/8-16 x 4 1/2", GR5	4
2	G9004020	Gauge Wheel	4
3	G3260016	Gauge Wheel Axle, 3/8" ID	4
4	G3260010	Gauge Wheel Fork	4
5	G3260012	Long Spacer	12
6	G3360004	Gauge Wheel Mount, LH	1
7	G9003501	Drive Wheel Bearing	8
8	G3260011	Short Spacer	4
9	F102	Klick Pin, 1/4"	4
10	G3360006	Upright Support	2
11	314020H5C	Hex Capscrew, 1/2-13 x 5 1/2", GR5	1
12	G3360003	Gauge Wheel Mount, RH	1
13	G3260013	Flexible Link Bushing	1
14	G3260003	Flexible Link	1
15	G3260004	Upright Brace	2
16	G9006300	Locknut, 7/8-14	2
18	G3360005	Knee	2
19	2738609	Category I Lift Pin, 7/8-14	2
20	G3360007	Knee Bushing	2
21	33003C	Hex Nut, 3/8-16	4
22	35003C	Lockwasher, 3/8"	4
23	33005C	Hex Nut, 1/2-13	11
24	35005C	Lockwasher, 1/2"	11
25	31407H5C	Hex Capscrew, 1/2-13 x 1 1/2", GR5	10
26	38005C	Flatwasher, 1/2"	8
27	450543	Self-tapping Grease Zerk, 1/4-28, 90°	4
28	32945C	Elastic Stop Nut, 1/2-13	2
29	314011H5C	Hex Capscrew, 1/2-13 x 2 1/2", GR5	2
30	37021C	Carriage Bolt, 5/16-18 x 3/4"	16
31	38002C	Flatwasher, 5/16"	16
32	35002C	Lockwasher, 5/16"	16
33	33002C	Hex Nut, 5/16-18	16
34	G3360008	Support Brace	2
35	G3260014	Support Bracket, LH	1
36	G3260015	Support Bracket, RH	1

## EM72 DECK

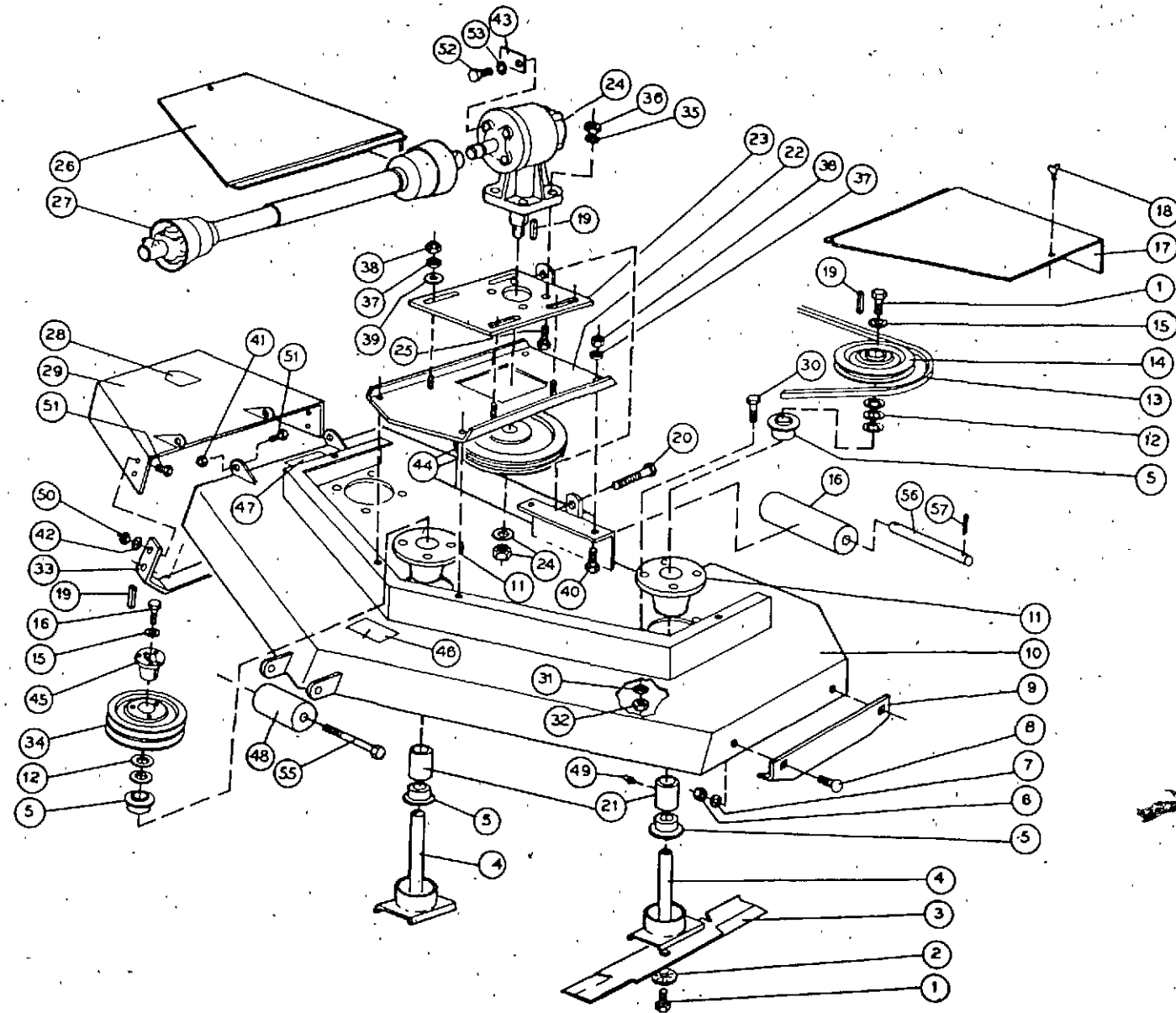

Item	Part No.	Description	Qty.
1	30206H5C	Hex Capscrew, 3/8-24 x 1 1/4", GR5	6
2	G9005534	Spring Washer	3
3	G9005608	Blade, 72"	3
4	G3450013	Spindle Shaft, 1" x 7 1/4"	3
5	G9003513	Spindle Bearing, 1"	6
6	33002C	Hex Nut, 5/16-18	22
7	35002C	Lockwasher, 5/16"	22
8	37021C	Carriage Bolt, 5/16-18 x 3/4"	22
9	G3450003	Shoe, LH	1
10	G3460000G	Deck, 72"	1
11	G3000025	Spindle Housing, 7/8" x 3 1/4"	3
12	G9006000	Machine Washer, 14 Ga. x 1"	14
13	G9003025	Blade Drive Belt, BX75	2
14	G9002549	Spindle Pulley, 6" OD x 1" Bore	2
15	G3000017	Spindle Washer	3
16	G9005559	Anti-scalp Roller, 3" x 9"	1
17	G3460003G	Pulley Box Cover, LH	1
18	G9006043	Thumb Screw, 1/4-20 x 1/2"	2
19	40621	Key, 1/4" x 1/4" x 1"	4
20	300311H5C	Hex Tap Bolt, 3/8-16 x 3", GR5	1
21	G3450015	Spindle Spacer	3
22	G3260002	Gearbox Adjustment Plate	1
23	G3260001	Gearbox Mount	1
24	2736461	Gearbox, 1 to 2.5 Ratio, 540 RPM	1
25	31407H5C	Hex Capscrew, 1/2-13 x 1 1/2", GR5	4
26	G3460002G	Pulley Box Cover, RH	1
27	2736462	Quick Disconnect IID Shaft	1
28	G9005549	Decal, Danger	1
29	G3300003G	Foot Guard	1
30	31306H5C	Hex Cap, 7/16-14 x 1 1/4", GR5	12
31	35004C	Lockwasher, 7/16"	12
32	33004C	Hex Nut, 7/16-14	12
33	G3300011	Shoe, LH	1
34	G9002540	Sheave, TBX 62H	1
35	35005C	Lockwasher, 1/2"	4
36	33005C	Hex Nut, 1/2-13	4
37	35003C	Lockwasher, 3/8"	8
38	33003C	Hex Nut, 3/8-16	8
39	38003C	Flatwasher, 3/8"	4
40	31205H5C	Hex Capscrew, 3/8-16 x 1", GR5	4
41	32941C	Elastic Stop Nut, 1/4-20	2
42	35001C	Lockwasher, 1/4"	6
43	2738608	ID Tag/No Oil In Gearbox	1
44	G9002545	Double Belt Drive Pulley, 10" OD	1
45	G9002547	Taper Bushing, SPS x 7/8" H x 1"	1
46	G9005542	Decal, Caution - Whirling Blade	1
47	G9005540	Decal, Caution - Grass Chute	1
48	G9005612	Anti-scalp Roller, 3" x 4 1/2"	1
49	45051	Self-tapping Grease Zerk, 1/4-28	3
50	33001C	Hex Nut	6
51	31003H5C	Hex Capscrew, 1/4-20 x 3/4", GR5	8
52	K9002530	Hex Capscrew, M8 x 12	1
53	38001C	Flatwasher, 1/4"	1
55	314021C	Hex Capscrew, 1/2-13 x 6"	1
56	G3460006	Roller Pin	1
57	49023	Cotter Pin, 1/8" x 1"	2

## EM72 CARRIAGE

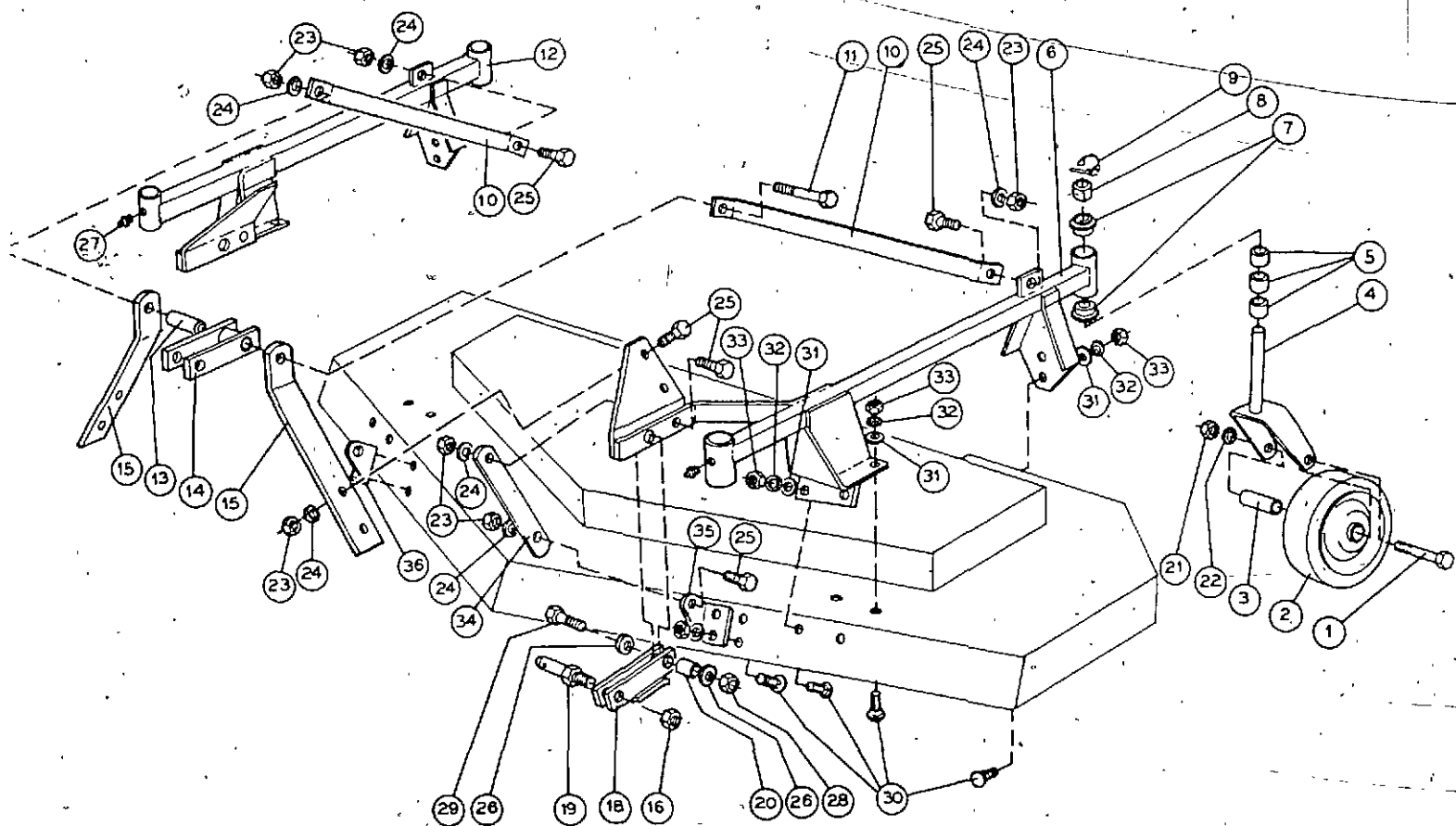

Item	Part No.	Description	Qty.
1	312018H5C	Hex Capscrew, 3/8-16 x 4 1/2", GR5	4
2	G9004020	Gauge Wheel	4
3	G3260016	Gauge Wheel Axle, 3/8" ID	4
4	G3260010	Gauge Wheel Fork	4
5	G3260012	Long Spacer	12
6	G3460005	Gauge Wheel Mount, LH	1
7	G9003501	Drive Wheel Bearing	8
8	G3260011	Short Spacer	4
9	F102	Klick Pin, 1/4"	4
10	G3460004	Support Brace	2
11	314020H5C	Hex Capscrew, 1/2-13 x 5 1/2", GR5	1
12	G3460004	Gauge Wheel Mount, RH	1
13	G3260013	Flexible Link Bushing	1
14	G3260003	Flexible Link	1
15	G3260004	Upright Brace	2
16	G9006300	Locknut, 7/8-14	2
18	G3360005	Knee	2
19	2738609	Category I Lift Pin, 7/8-14	2
20	G3360007	Knee Bushing	2
21	33003C	Hex Nut, 3/8-16	4
22	35003C	Lockwasher, 3/8"	4
23	33005C	Hex Nut, 1/2-13	11
24	35005C	Lockwasher, 1/2"	11
25	31407H5C	Hex Capscrew, 1/2-13 x 1 1/2", GR5	10
26	38005C	Flatwasher, 1/2"	8
27	45051	Self-tapping Grease Zerk, 1/4-28	4
28	32945C	Elastic Stop Nut, 1/2-13	2
29	314011H5C	Hex Capscrew, 1/2-13 x 2 1/2", GR5	2
30	37021C	Carriage Bolt, 5/16-18 x 3/4"	16
31	38002C	Flatwasher, 5/16"	16
32	35002C	Lockwasher, 5/16"	16
33	33002C	Hex Nut, 5/16-18	16
34	G3360008	Support Brace	2
35	G3260014	Support Bracket, LH	1
36	G3260015	Support Bracket, RH	1

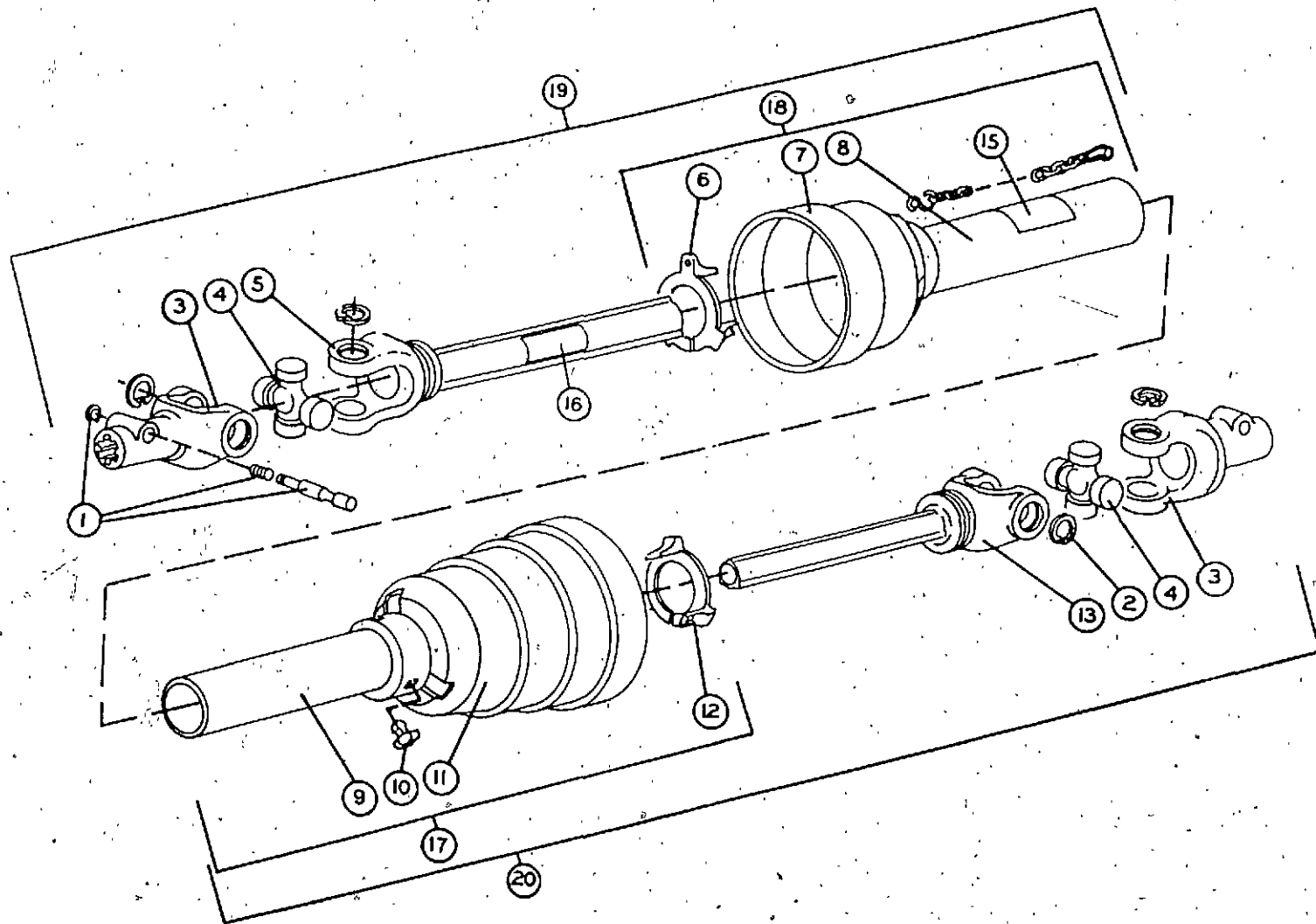

### IID DRIVE SHAFT

Shaft Assembly 2736462

Item	Part No.	Description	Qty.
1	2716615	Push Pin Set	2
3	2716713	Push Pin Yoke	2
4	2716714	Cross Journal Set	2
5	2716715	Outer Tube Yoke	1
6	2716718	Retaining Collar	1
7	2716719	Outer Hub Cone	1
8	2716720	Outer Tube	1
9	2716721	Inner Tube	1
10	2716623	Nylon Bolt	6
11	2716722	Inner Hub Cone	1
12	2716717	Retaining Collar	1
13	2716716	Inner Tube Yoke	1
15	2738315	Decal, IID Shield	1
16	2738320	Decal, IID Shield Removed	1
17	2716726	Inner Shield Half	1
18	2716725	Outer Shield Half	1
19	2716723	Female Shaft Half	1
20	2716724	Male Shaft Half	1

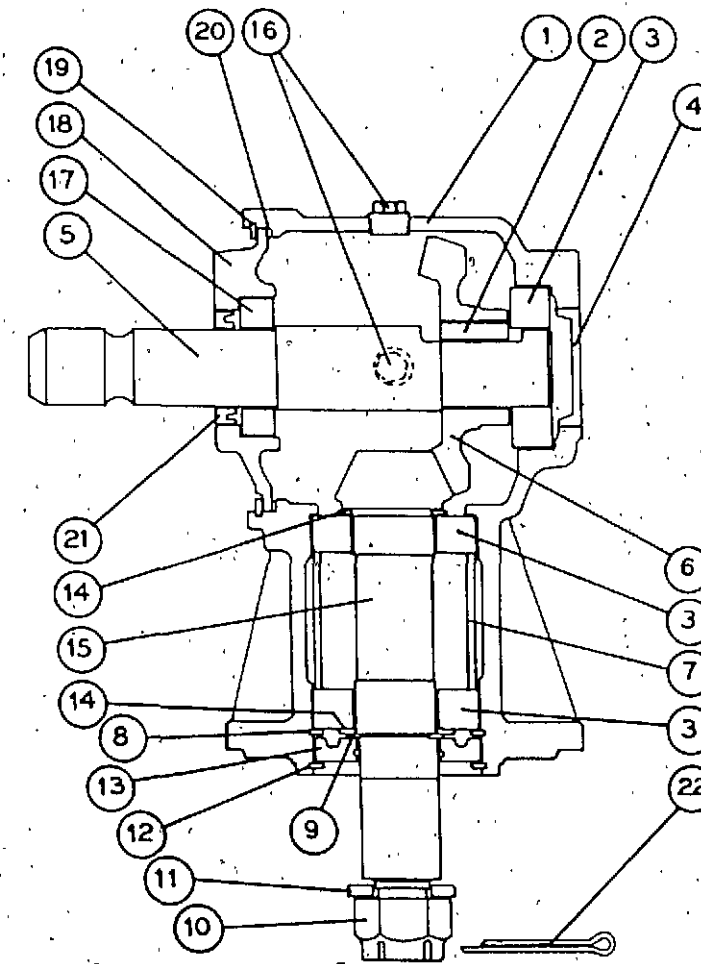

### GEAR BOX

Gearbox 2736461

Item	Part No.	Description	Qty.
1	2716699	Casing	1
2	2716700	Key, B10 x 8 x 70	1
3	2716539	Bearing, 6207	3
4	2716701	Cap, 52 x 7	1
5	2716702	Shaft, 1 3/8", Z6	1
6	2716703	Gear, Z30 M3.8	1
7	2716704	Spacer	1
8	2716537	Snap Ring, 72, UNI7437	1
9	2716705	Snap Ring, 35, UNI7435	1
10	2716706	Castle Nut, M24 x 2	1
11	2716604	Washer, 25 x 44 x 4	1
12	2716707	Snap Ring	1
13	2716708	Double Lip Seal, 35 x 72 x 12	1
14	2716709	Shim Kit	2
15	2716710	Pinion Shaft, Z12, M3.8	1
16	2716420	Vent Plug, 3/8"	2
17	2716711	Bearing	1
18	2716712	Cover	1
19	2716609	Snap Ring	1
20	2716612	O-ring	1
21	2716611	Oil Seal, 35 x 52 x 7	1
22	2716614	Cotter Pin, B5 x 50	1